

8 7 6 5 4 3 1

REVISIONS				
REV	DESCRIPTION	ECN	DATE	DRN APR
-	ISSUE DRAWING		051601	MDC

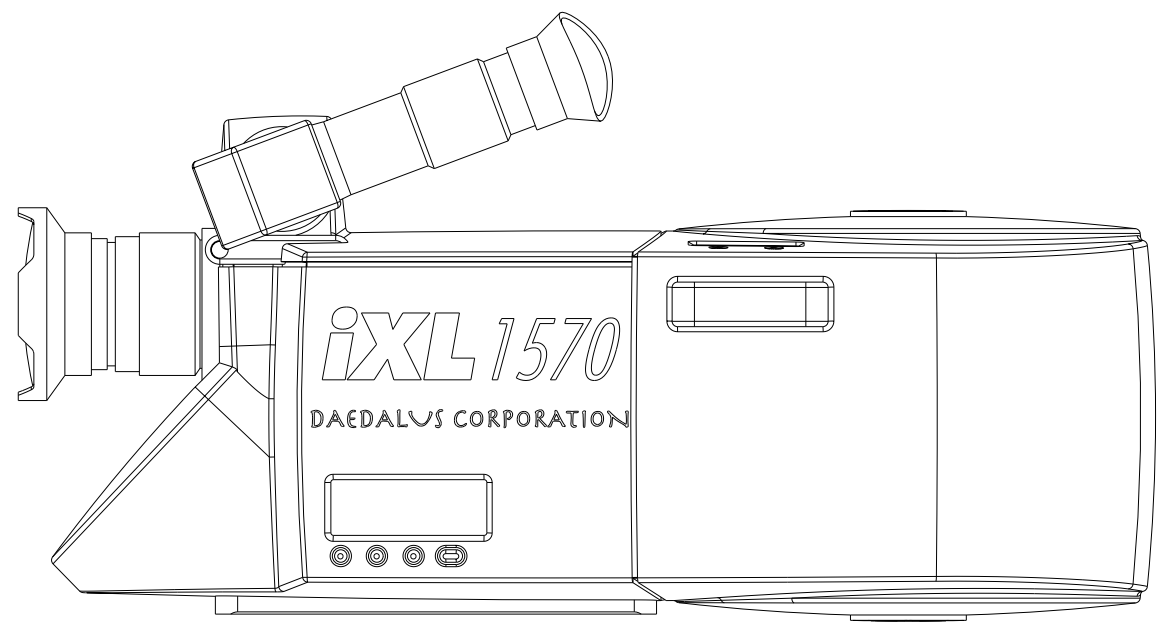
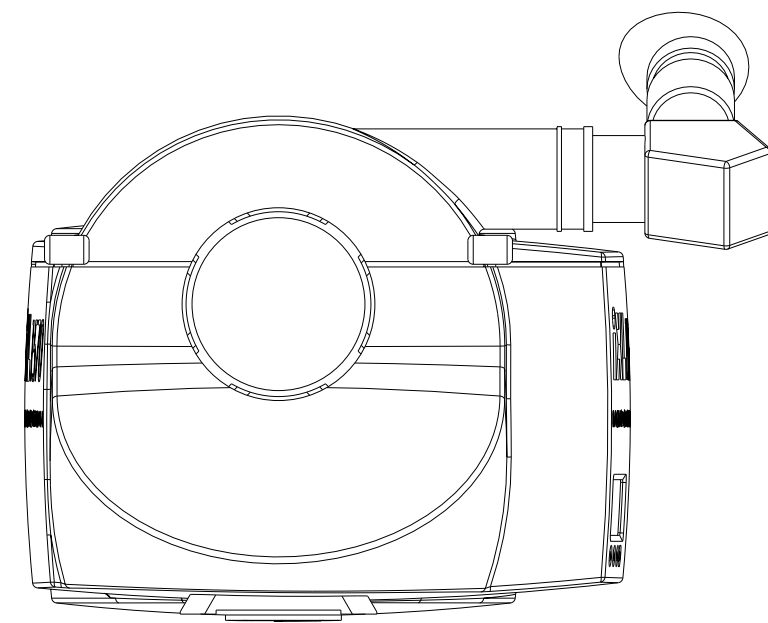
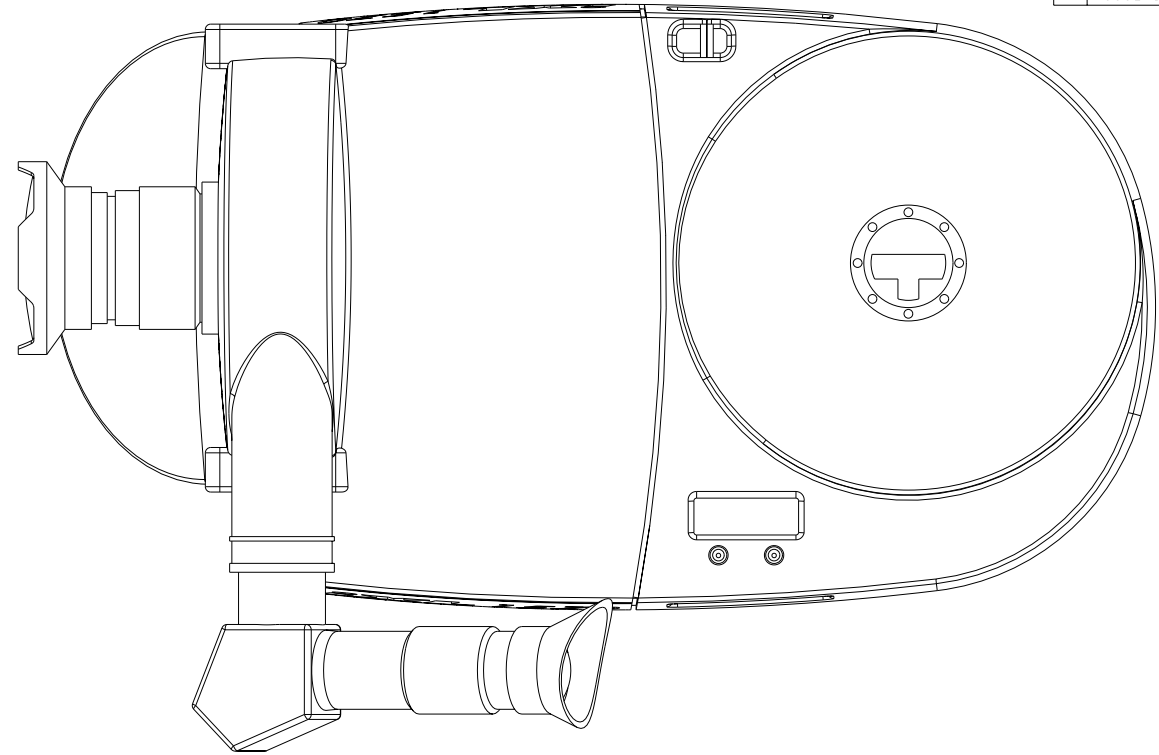
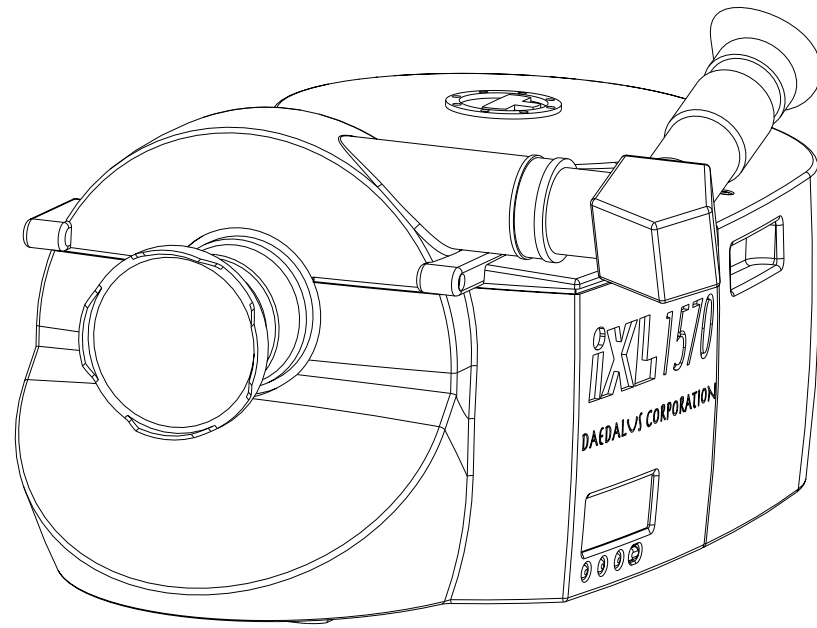

DESIGN GOALS:
 WEIGHT W/ LENS & FILM 35 LBS W/500', 42 LBS W/1000'
 MIRROR REFLEX VIEWING
 FLICKER-FREE B&W VIDEO ASSIST
 VIDEO DATA INSERTS CAMERA & FOOTAGE DATA
 FIXED LOOP 500FT AND 1000FT MAGAZINES
 TIME TO RELOAD: LESS THAN 30 SECONDS
 FOOTAGE DISPLAY ON MAGAZINE
 OPERATING VOLTAGE: 22 - 38VDC
 DIGITAL SMT, PLUG & PLAY ELECTRONICS
 ELECTRONICS BOARDS REPLACEABLE ON LOCATION: 3 MIN
 OPERATING SPEEDS: 1 TO 48FPS @ 1/1000 SEC STEP
 OPTIONAL VARI-SPEED
 60 FPS HIGH SPEED

FULL FEATURED - BUILT IN REMOTE CONTROL
 VACUUM BACK
 LOSS OF VACUUM ALARM
 GLOWING VIEWFINDER LINES
 HEATED EYE-PIECE
 100 FT REMAINING LED
 BUILT-IN TIMELAPSE
 OPTIONAL COMPUTER MOTION CONTROL

QUANTITY	PART NO.	DESCRIPTION	ITEM NO.
PARTS LIST			
PROPRIETARY THIS DRAWING AND ALL INFORMATION THEREIN IS THE PROPERTY OF DAEDALUS CORP. THIS DRAWING MAY NOT BE REPRODUCED OR MADE PUBLIC WITHOUT PERMISSION, AND IS SUBJECT TO RETURN UPON DEMAND.		DAEDALUS CORPORATION 1212 N. BERKELY AVE. TURLOCK, CA 95380 TEL (209) 668-2955 FAX (209) 668-4010	
FINISH TOLERANCES UNLESS OTHERWISE SPECIFIED UNITS - INCHES X.X = ±0.05 X.XX = ±0.01 X.XXX = ±0.005 ANGLES = ±1.0°		DO NOT SCALE DESCRIPTION LIGHTWEIGHT 1570 CAMERA	
DRAWN BY M. CLAUSEN		DATE 051601	
DESIGN BY		SIZE D	
APPROVED BY		DRAWING NUMBER IXL_1570	
		REV -	
		SCALE: 0.500 SHEET 1 OF 1	

D
C
B
A

D
C
B
A

8 7 6 5 4 3 2 1